

CIRCULAR THREADING TOOLS
ON 22 3350

Shell Type for Male Metric Treads

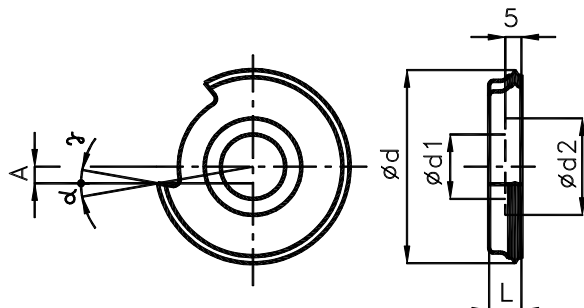

Cutters of high – speed steel (HSS) or extra high – speed steel (HSSE) are available. The tools are intended for cutting right – hand and left – hand male threads with advantage of cutting up to the face. The tools are chucked in holders – ON 241582. The special design allows for the use of tool in the right – hand and left – hand thread cutting. In a special version, tools with $\varnothing d$, $\varnothing d1$, $\varnothing d2$ and α , γ angles and tools with dimensions at the option of the customer, are available.

s	L h16	$\varnothing d$ h16	$\varnothing d1$ H7	$\varnothing d2$ H12	α	γ	A	G
0.5	10	63	20	30	10	10	5.5	0.22
0.6								
0.7								
0.75								
0.8								
* 0.9								
1								
1.25								
1.5								
1.75								
2								
2.5								
3								
3.5								
4	11	63	20	30	10	10	5.5	0.24
4.5								
5								
5.5								
6								
6								

Dimensions marked * are not specified in ČSN. Dimensions in mm.

Legend:

s ... pitch [mm]
 α ... cutting clearance angle [°]
 γ ... rake angle [°]
 A ... withdrawal
 G ... weight [kg]